

SLG-24F, SLG-24FH

Photoelectric Smoke Detector

The SLG Type Photoelectric Smoke Detector incorporates, through computer design, the finest in detector technology. Not only is response to smoke enhanced by the non-directional, dual ramp smoke chamber, but this chamber design reacts positively to flaming fires. Optionally Model SLG-24FH has a fixed temperature, 135°F, self restoring, heat detector mounted in the nose of the detector and is Listed for 50 ft. spacing.

All SLG's include an externally mounted Status LED which blinks so long as the detector is powered. This LED lights continuously when the detector is in alarm. This Status LED automatically re-sets when the detector is re-set.

Testing the smoke sensing function of the SLG-type is easily performed. A reed switch has been included in the circuit which when activated by an external magnet, reacts as if the detector were subjected to a level of smoke of approximately 4% per foot of obscuration. This same test feature is used to excite the detector when determining the actual sensitivity value during the use of the TSI-A100 Sensitivity Monitor. This electro/mechanical test method eliminates the need to use smoke or smoke substitutes in environmentally unstable or environmentally clean areas. The heat detector is tested by applying heat directly to the heat detector element.

OPERATION

The unit is comprised of a LED light source and silicon photo diode receiving element. Normally, the receiving element receives no light from the pulsating light source. In the event of fire, smoke enters the detector and light is reflected from the smoke particles to the receiving element, where it is converted



Pictured is MODEL SLG-24FH

into an electronic signal. Signals are compared in the comparator and when two signals exceeding the basic level are received in series within a specified period of time, the time delay circuit triggers the SCR switch to activate the alarm signal. At this time the alarm LED lights steadily.

The heat detector operates independently of the smoke sensing circuit. Though it will initiate the alarm on its own it does not light the LED on the smoke detector head during the alarm period.



ALPHA-LARM A Division of HOCHIKI AMERICA CORPORATION

5415 INDUSTRIAL DRIVE, HUNTINGTON BEACH, CA 92649 • (714) 898-0795

APPLICATIONS

The SLG Detector has responsive yet high operational stability that gives it an extremely wide range of uses. It is suitable for use in areas of high humidity, high altitudes, high air velocities, and all temperature extremes set forth by Underwriters' Laboratories, Inc.

Its high impedance circuitry and well buffered inputs are effective against outside electrical interference. This assures a high degree of operational integrity.

The SLG Detector with its HS style base is compatible with all other Hochiki America detectors, past and present, and may be intermixed with or used as replacements for our other detectors and their bases on the same system. All SLG Detectors have normally open contacts. They may be used with other normally open contact devices like manual stations, panic switches, etc. as needed.

Current compatible detection devices offered by Hochiki America are the SIF-24F ionization smoke detector, either the DCA or DFE heat detectors, and the HF-24 flame detector. Only the smoke detectors will have alarm LEDs unless special latching bases are used on the heat detectors.

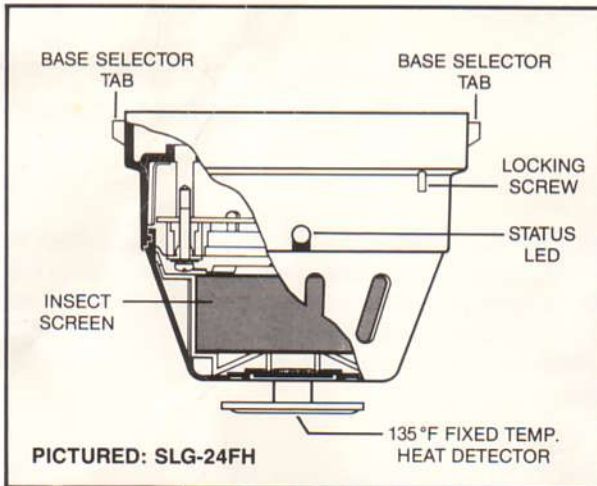
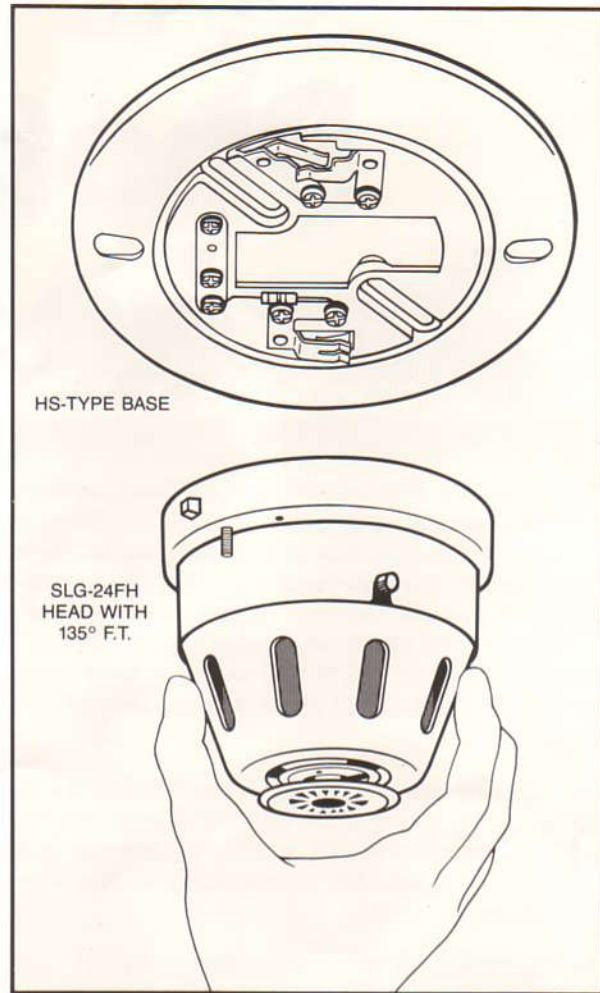

NOTE: The "Base Selector Tabs" prevent the smoke detector head, which contains its own alarm LED, from being used in a base which contains an Alarm LED. To do so, might result in a non-functioning fire alarm system.

GENERAL DATA

RATED VOLTAGE	17.6 — 27.7 VDC
WORKING VOLTAGE	15-30 VDC
SURGE CURRENT <i>in per spec</i>	200 μ A @ 24 VDC
NORMAL CURRENT	40 μ A @ 24 VDC
ALARM CURRENT	.150 AMPS MAX. @ 24 VDC
LIGHT SOURCE	INFRARED LED
HEAT DETECTOR	135°F SELF-RESTORING F.T.
AMBIENT TEMPERATURE	+ 32°F — + 120°F (0°C - 49°C)
MOUNTING	4" OCTAGONAL OUTLET BOX*
COLOR	BONE WHITE
HUMIDITY	95% R.H. MAX.

*The HS Base also mounts to 3-O and 4-S boxes.