



INSTALLATION INSTRUCTIONS FOR THE MODEL FFO-SBASE ANALOG SOUNDER BASE

The information contained in this installation instruction is a quick reference guide. For detailed system information refer to the panel manufacturer's installation manual. This instruction will not address specific programming procedures.

GENERAL DESCRIPTION

This instruction applies to the model FFO-SBASE analog sounder base, which is to be connected to a DCP Signaling Line Circuit (SLC). The FFO-SBASE is to be used with the FFO-SMOKE & FFO-HEAT model sensors only. The FFO-SBASE provides an audible alarm in the immediate vicinity. Typical applications are for use in hotels, apartments, and hospitals.

MOUNTING REQUIREMENTS

BASE	BOX MOUNTING		
	3" OCT	4" OCT	4" SQR
ALL MODELS	YES	YES	NO

WIRING

NOTE: All wiring must conform to local codes, ordinances and regulations.

- 1) **This is a warning.** Connect wiring to terminals as shown. Do Not loop wire under terminals. Break wire run to provide supervision of connections.
- 2) Install base wiring in accordance with the applicable drawings and appropriate wiring diagram (see Figures A and B).

CAUTION!

To ensure proper operation connect this base to a compatible Fire Control Panel only. Refer to panel instructions for proper connection and compatibility.

CAUTION!

If this base will be installed in an existing operational system, inform the operator and local authority that the system will be temporarily out of service. Disconnect power to the control panel before installing the base.

CAUTION

Install the bases in this instruction in accordance with applicable NFPA standards, local codes, and the authorities having jurisdiction. Failure to follow these instructions may result in failure of the detector to initiate an alarm condition. Hochiki America is not responsible for detectors that have been improperly installed, tested, or maintained.

For testing and cleaning information refer to Technical Bulletin HA-96. Also refer to NFPA-72 Chapter 2 & 7 for Automatic Fire Detectors for installation guidelines, testing, and maintenance.

Use "3M" Weatherban # 606 nonflammable sealing compound to seal field wiring conduit openings in the mounting back box. Compliance with this request may reduce the occurrence of the "STACK EFFECT".

SPECIFICATIONS

Model	FFO-SBASE
DCP Voltage Range	17-41VDC
DCP Loop Idle Current	110 μ A
DCP Loop Max. Alarm Current	110 μ A
Aux. Power Supply Voltage Range (See Table Number of Bases Permitted)	16-31VDC
Device aux power min. voltage	15.0 VDC
Aux. Idle Current	550 μ A
Aux. Max. Alarm Current	18mA
Max Humidity	93%RH (non-condensing)
Sound Pressure Level at 10 ft	85 dB
Operating Temperature Range	0°C (32°F) ~ 38°C(100°F)
Storage Temperature	-30°C (-22°F) ~ 70°C(158°F)
Base Diameter	5.94"
Base Height (without sensor)	1.34"
Weight	0.455 lb
Compatible Detectors	FFO-SMOKE & FFO-HEAT

NUMBER OF BASES PERMITTED

# of Bases In Alarm	Maximum Aux. 24VDC Power Wire Resistance (Total Auxiliary Run Length)
127	1.4 ohm
75	2.4 ohm
60	3.0 ohm
50	3.6 ohm
30	6.1 ohm
20	9.1 ohm
15	12.2 ohms
10	18.3 ohms

NOTE: SLC maximum wiring resistance is 50 ohms.

Calculations based on FireFocus panel 18.3V Auxiliary at panel and 15V minimum Auxiliary at Device.

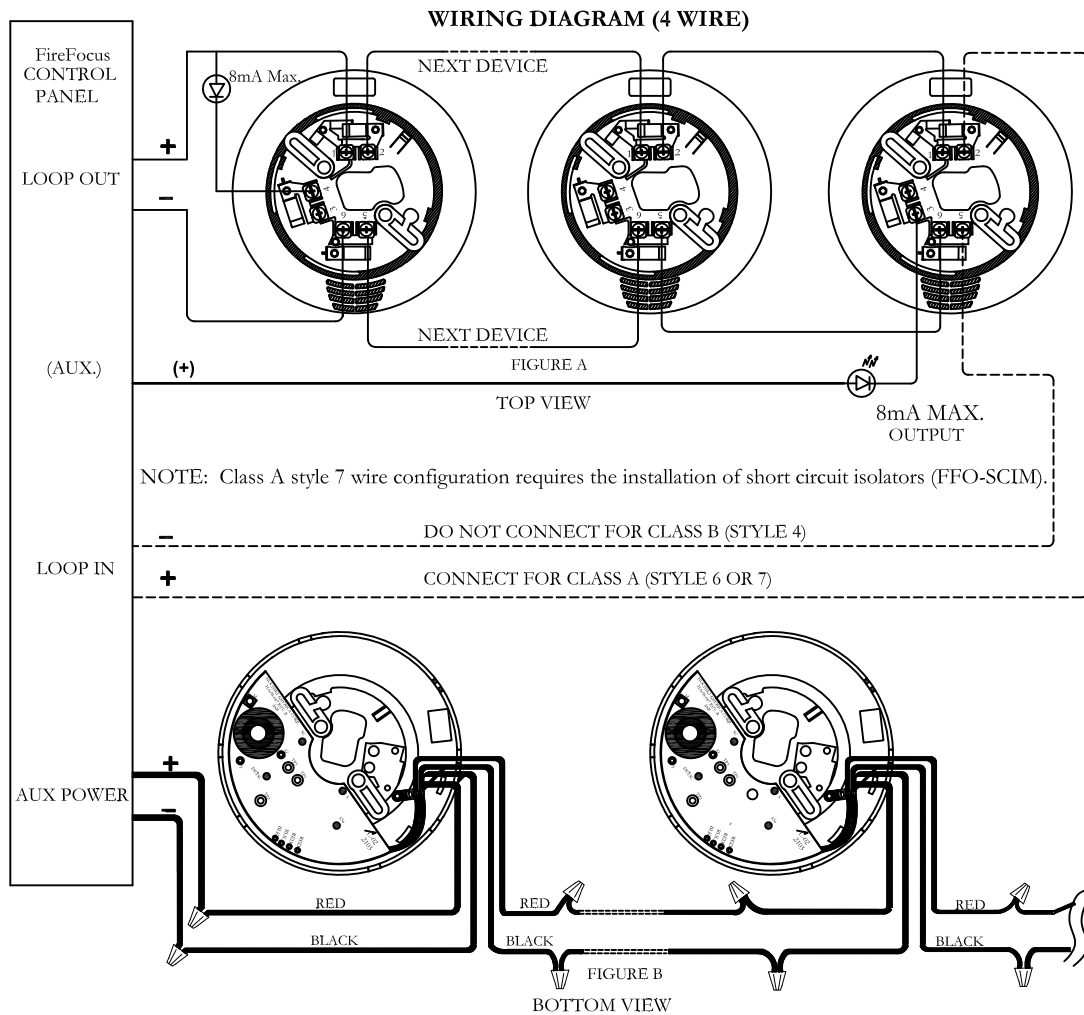

Mounting Instructions

Please refer to diagram in Figure 1

The Model FFO-SBASE sounder base mounts directly to 3" or 4" octagonal boxes. To mount the base, remove the back cover from the main assembly and place flush onto a back box. Attach the cover using the (2) 8-32 x 1 3/8 mounting screws (supplied). Once the back cover is mounted securely to the box, snap the main assembly into place by aligning the notches on both pieces of the plastic housing. Complete the assembly by fastening it using (2) standoff screws (supplied) into the appropriate slots.

